

96"x 48" Rectangular Commercial Grade Plywood Folding Banquet Table, Vinyl Edge

Rugged Okoume Plywood Vinyl Edge Construction

Features a sleek, smooth vinyl edge that wraps around the table.

Fastened with Marine-grade steel bolts, with a strength grade of 8.8., and a tensile strength of 400N/mm and sheer strength 8x tensile.

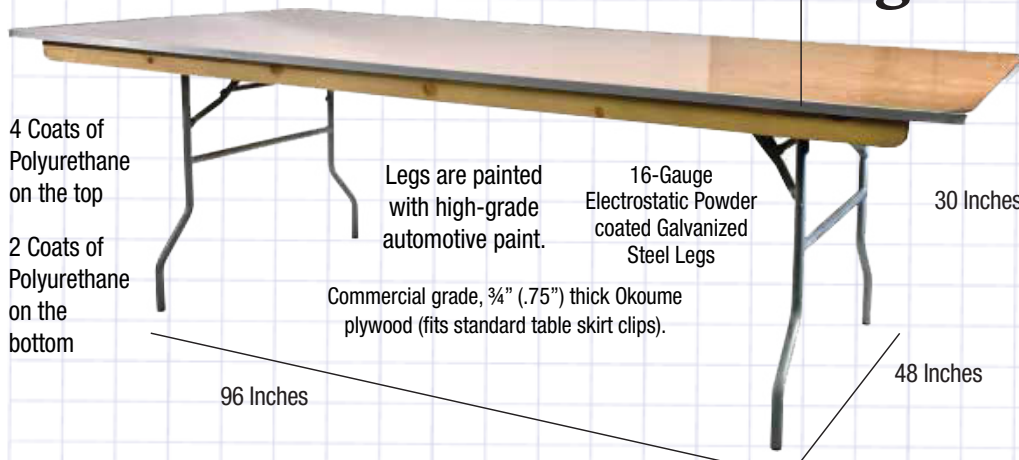

Posi-lock wishbone legs that fold easily but do not open during transport.

11 Layers of Okoume Plywood

Not 8 or 9-Ply like other tables. Our Okoume Plywood Table is 11-Ply, plus 5 layers of polyurethane.

Not 6 Layers...

Most tables are built with six layers of ordinary plywood



Not 9 Layers...

Better tables use 9 layers of ordinary plywood.



We use 11 Layers

Then our vinyl banding is applied, with tons of pressure, locking hardware and folding 16-gauge Galvanized Steel Legs.



What Makes Our Tables Different: 13 Okoume Wood Layers

Our exclusive aluminum EdgeMAX Tables are made from 11 layers of premium-grade Okoume wood, plus two wood veneer layers -- that's 13 layers of wood which deliver exceptional strength. In addition, there are three applied layers of polyurethane to the top surface, and two coats to the bottom for a total of 18 layers of protection!

Over 80% of steel joints are precision welded by robots and sophisticated welds are added by hand. All welds are reviewed and certified by a master welder. And our Cold Formed™ steel alloy bolts improve physical strength and longevity. The steel we use is recyclable at metal recycling plants across the country

We Bolt Our Table Tops To Their Frames (others don't)

Other Tables (screws)

Our Tables (Bolts)



They use screws to secure the table top to the frame. Not as strong or as stable!

Our frames and table tops are fastened with lock nut and washer.

Our tables are stronger because every joint is extra strong. While other inferior tables use a single screw to attach the table top to the framing, our table tops are bolted to their frames, with a lock nut and washer before the nut. Supports combined leg strength of 1,760 pounds

Okoume plywood is made from sustainably grown and renewable lumber.



Material	3/4" Commercial Grade Plywood
Shape	Rectangle
Size	96" x 48" x 30"
Commercial-Grade?	Yes
Edge Material	Vinyl
Folded Dimensions	2.25"
Legs	16-Gauge, powder coated Steel
Leg Color	Silver
Replaceable Floor Caps	Yes
Overall Length / Depth	96"
Overall Height	30"
Overall Width	48"
Tablecloth Size(s)	60"x102", 60"x126", 90"x132
Recommended Seating	8
Ships Assembled?	Yes
Product Warranty	1 Year
Weight Capacity	670 lbs.
Item Weight	60 lbs

Bottom Runners 2 runners on the table bottom prevent warping and allow table stacking. The Posi-lock wishbone legs fold and lock easily.

Our ToughEdge Our reinforced ToughEdge protection strip surrounds the entire table and can withstand years of setup and breakdown.

Bolt-Through assembly Our tables are crafted using only a commercial-quality Bolt-through assembly process for ultimate strength.

High-Strength Bolts Cold Formed™ steel alloy bolts for improved physical strength and longevity